

Exploring Power Signatures for Location Forensics of Media Recordings

Technical Report of the UNStoppable team

Authors: Danica Despotović, Milivoje Knežević, Željana Šarić, Tijana Zrnić, Anastazia Žunić
Tijana Delić, tutor, Nikša Jakovljević, supervisor
danica.despotovic@gmail.com, micko93ns@live.com,
zeljana_saric@yahoo.com, tijana.zrnic@yahoo.com, anastazia.zunic@uns.ac.rs
tijanadelic@uns.ac.rs

Faculty of Technical Sciences, University of Novi Sad
Novi Sad, Serbia

Abstract - The Electric network frequency (ENF) signal is a unique signal for different parts of the world. It is captured by electric devices, and can be used in authentication and automatic synchronization of digital media recordings. In this paper we propose an algorithm to extract ENF from power and audio recordings, and use ENF criterion to identify the region-of-recording. We also propose a design of a circuit to record the electrical power grid. The ENF extraction was performed on one of the three highest peaking harmonics in the spectrum, using Discrete Fourier transform (DFT) in case of audio and Estimation of Signal Parameters via Rotational Invariance Techniques (ESPRIT) method in case of power recordings. The classification tool used was a set of binary support vector machines (SVM). Different combinations of features were used for each classification subgroup, resulting in 92% success rate on the Practice dataset, and 86% on cross-validation with the Training dataset, both containing recordings from 9 different grids. The sensing circuit, constructed with Hall effect sensor and Arduino UNO, was used to obtain over 10 hours of recordings of the Serbian power grid.

Index Terms – Binary SVM classifier, Electric network frequency, ENF extraction, Hall effect sensor, Power grid measurements

I. INTRODUCTION

The Electric Network Frequency (ENF) is the utility frequency of a power grid and as such, ENF represents one of its main features. While directly measurable at e.g. wall sockets, power line signal also gets captured when recording audio or video signals in such an environment. The behaviour of the ENF signal is shown to be similar and, more importantly, stable across the whole network, possessing traits distinctive enough to serve as a “natural fingerprint” of a network [1]. ENF signals are used in various fields, including forensic authentication and detecting forgery of ENF-containing multimedia signals, as well as inferring their time and location of creation [2-5]. Another potential

usage of the ENF signals can be found in automatic synchronization of audio and video [6]. The ENF criterion has most recently been employed in a forensic technique for determining the time when a digital audio recording was made and determining the authenticity of evidential digital audio recordings [7]. This method is based on analysing the signal corresponding to the fundamental frequency of the voltage in the electrical network, which is present in the given recording, and comparing it with an appropriate, reliable reference database designed in a laboratory or obtained from the electric network company. Recent years have shown a significant increase in the number of attempts to use digital audio or video evidence in every sector of litigation and criminal justice. An ENF analysis of an audio or video signal is a strong tool to identify a forgery or falsification, and thus the introduction of ENF analysis represents a breakthrough in the quest for forensic techniques that will defeat the efforts of the audio/video forger operating in the digital domain [4].

The nominal value of utility frequency varies from one part of the world to another. The nominal value of 60 Hz is present in Canada, USA, South America, and some parts of Africa, whereas it is 50 Hz in Europe, Australia, and the remaining parts of the world. It is also possible that in one country two nominal values are used, e.g., for the west side of Japan the nominal value is 60 Hz, and for the east side it is 50 Hz [5]. Regardless of its nominal value, the frequency of an electric network usually fluctuates around its supposed value due to the load variations in the grid. These fluctuations are significant since they define the ENF signal over time. The range can depend on the size of the grid, where a smaller capacity grid often has a higher range of fluctuations, whereas those with a larger capacity can be controlled with relative ease [5]. The previously conducted research has shown that the ENF signal across a connected power grid is similar at a

given time period, but can have inter grid variations, caused by different local conditions in a city or across several cities [8]. So far, papers exploring this topic conclude that the ENF signals tends to be more similar at locations which are closer to each other, than those further apart. For that reason it would be beneficial to have a database with ENF data for a larger set of locations, to increase the accuracy of identification [6].

Spectral analysis is a mean for investigating the spectral content of a signal by either nonparametric or parametric techniques. Non-parametric or classical approaches are based on the Fourier analysis of a signal (e.g., periodogram, correlogram, and modified versions of them). The second approach to spectral estimation is to hypothesize a model for the data, which provides a way to parameterize the spectrum, and thus reduces the spectral estimation problem to that of the parameter estimation for the assumed model [9]. Parametric approaches have shown to be more efficient in this field. In previous research, described in [8], the methods of choice were Multiple Signal Classification (MUSIC) and Estimation of Signal Parameters via Rotational Invariance Techniques (ESPRIT). The latter is based on subspace analysis of signals and noise model using the correlation coefficient, gives the most accurate results for the ENF signal estimation in terms of temporal and frequency resolution.

In this paper, an algorithm for ENF extraction and subsequent classification of the origin of the grid is proposed. The paper also describes the design of a sensing circuit for the power grid, as well as the procedure by which over ten hours of recordings was collected.

II. EXTRACTION OF ENF SIGNALS

A. Database

The database used in this paper consists of power and audio signals from 9 different power grids, named from A to I. Every grid is represented by between 8 and 11 power signals and 2 audio recordings. All audio signals are of equal length of 30 minutes. On the other hand, power signals have variable length, ranging from 15 minutes to 1 hour. Every grid in the database is represented with a different amount of data. Three out of nine grids, namely A, C, and I, have a nominal frequency of 60 Hz, while the others have a nominal frequency of 50 Hz.

B. Algorithm

The core functionality of the ENF extractor is to filter audio and power signals in order to acquire a denoised signal carrying ENF properties of the grid. A decision tree is formed, and in doing so power and

audio signals are treated differently depending on the nominal network frequency.

Firstly, a vector of frequencies is obtained by estimating the zero-crossing rate of the input signal. If the standard deviation of the zero-crossing rate of the input signal is below the threshold of 10Hz, the input signal is classified as a power signal, otherwise it is classified as an audio signal. The second decision concerns the nominal grid frequency. The three highest peaks in the spectrum around integer multiples of 50 and 60 Hz are taken into consideration, in order to avoid spurious estimates. The one with the greatest amplitude is chosen as the frequency where filtering and the ENF extraction itself will take place.

In the case of power signals, the signal is filtered around the previously obtained frequency using an equiripple FIR filter. Following the filtering, the signal is then divided into 5-second long overlapping segments, and each one is multiplied by the Hamming window. The starting points of successive segments are 1 second apart. The standard ESPRIT method is used for estimating the frequency. Therefore, one value per second is obtained.

If the input signal is classified as audio, it is divided into overlapping segments using Hamming windows of length 10 seconds, shifted by 1 second. The reason for adopting different window lengths for power and audio recordings lies in the desire to reduce processing time, since the ENF extracted from power recordings shows no significant difference when 10-second segments are used. The spectrum is computed with Discrete Fourier transform, implemented in MATLAB as Fast Fourier transform (FFT). The highest peak within 20% of the previously acquired frequency in the spectrum of a segment is used for obtaining ENF, resulting in one estimate per second. In case of detection of great fluctuations, they are treated as false ENF estimates, and are consequently removed. If the difference between the two successive samples is more than 0.15 Hz, it is removed by assigning the value of the first sample to the subsequent; also, if this algorithm is performed more than 15 times, or the range of the signal is less than 0.02 Hz, the whole procedure is repeated with the different chosen frequency from the three maximum ones obtained. If none of these three frequency estimates leads to satisfactory results, the system returns the ENF signal approximation by using the first estimate, i.e. the one with the greatest amplitude. The resolution of ENF signal obtained in this manner is 0.5 mHz. When the ENF is extracted from a multiple of 50 or 60 Hz, either power or audio, it is divided by the order of the harmonic. Fig. 1-4 show the ENF signals extracted from both audio and power recordings from grids with different nominal frequency.

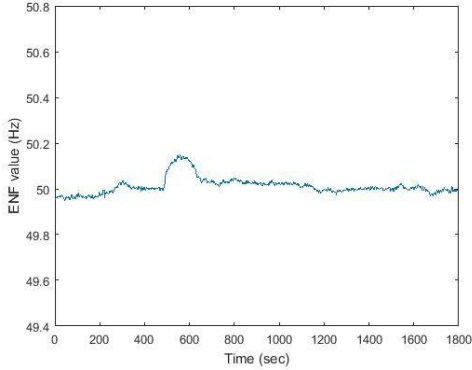

Fig. 1. ENF signal extracted from an audio recording from grid G.

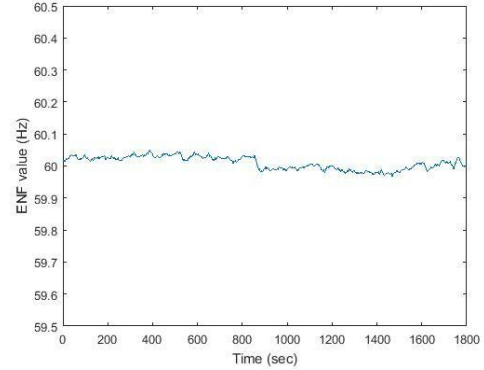

Fig. 2. ENF signal extracted from an audio recording from grid I.

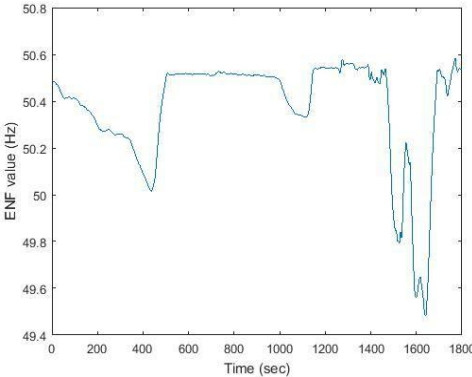

Fig. 3. ENF signal extracted from a power recording from grid B.

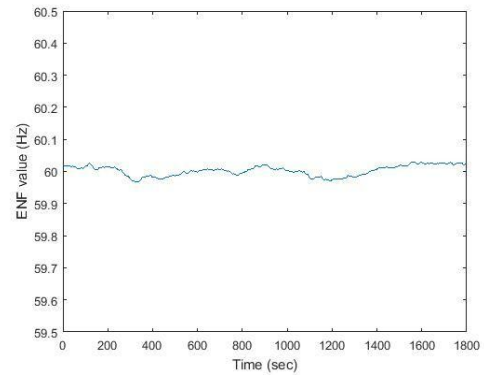

Fig. 4. ENF signal extracted from a power recording from grid C.

III. ENF CLASSIFICATION

The classification of signals according to their originating grids follows the ENF extraction. Based on the nominal value of the input signal and the decision on its type (audio or power), the signal will be classified using one of the 4 classifiers, according to extracted features. The first classifier is for power signals with nominal network frequency of 50 Hz, which is trained on power signals from 6 different grids with nominal network frequency of 50 Hz. The second classifier is for power signals with nominal frequency of 60 Hz, which is trained on power signals from 3 different grids with nominal value of 60Hz. The third classifier is for audio signals from grids with nominal frequency of 50 Hz, which is trained on both audio and power signals from 6 different grids with nominal value of 50 Hz. The fourth classifier is for audio signals from grids with nominal frequency of 60 Hz, which is trained on both audio and power signals from the remaining 3 grids with nominal frequency of 60 Hz. Each classifier, as a result, returns the label of the recognized grid from the training set, or classifies the signal as unknown, which means that it does not belong to any of the grids from the training set.

A. Feature set

After a detailed analysis of ENF signals, it can be noticed that certain signal features are more discriminative than others. Consequently, the features used for location identification were the following: mean and range of ENF signals, the coefficients obtained by wavelet decomposition and the Yule-Walker method, values connected with the extrema present in the signal, as well as values connected with rising edges present in the signal.

By finding the mean of the ENF signal it can be easily distinguished if its nominal value is 50 Hz or 60 Hz. Furthermore, even the signals with the same nominal frequency could be separated based on their respective mean value. In order to calculate the dynamic range of the signal the minimum value of the signal was subtracted from its maximum value. The variance was not considered since it was found to be highly correlated with the range of the signal.

Since ENF is time-variable, wavelet decomposition was considered to be a suitable transformation to observe both frequency and time changes [10-11]. The original ENF signal was decomposed into N levels, with symlet wavelet family as the base. The optimal value of N was computed:

$$N = \log_2(\text{signal_length}), \quad (1)$$

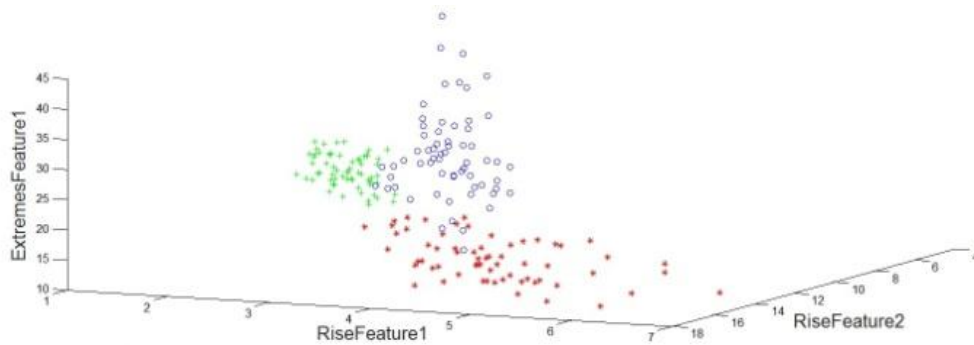

Fig. 5. Scatter plot for features of 60 Hz power recordings

which resulted in a 12-level decomposition for the longest ENF signal, hence used for all ENF signals [11]. The value of the logarithm of the standard deviation of the approximation after all 12 levels of each level of detail represented additional 13 possible features. The Yule-Walker method is an approach that uses the Yule-Walker (or Normal) equation for estimating the autoregressive (AR) parameters. The values used as features were 3rd and 4th coefficients, as well as the estimation of variance of the white noise, both obtained from the Yule-Walker AR model of the 4th order [8].

Another two features were obtained observing the extrema in the ENF signal. The first one represents the percentage of the points in which the first derivative changes its sign, i.e. the number of local minima and maxima divided by the length of the ENF signal. The second feature is the standard deviation of a vector containing the maximum difference between a local extremum (maximum or minimum) and its two nearest neighbours (predecessor and successor), or zero if the point was neither a local minimum nor a local maximum. These features are named *extremes_feature1* and *extremes_feature2*. Finally, the last pair of features are those related to a change of monotonicity in the signal. The sum of the rising edge points is stored into one vector, while the other one carries the information about the index of the last rising edge point. The mean values of both vectors are calculated and used as features *rise_feature1* and *rise_feature2*. The scatter plot of features for power signals from 60Hz grids is shown in Figure 5. Axes *x*, *y* and *z* show *rise_feature1*, *rise_feature2* and *extremes_feature1*, respectively.

B. SVM classification

A supervised learning model was chosen for classification, specifically a binary support vector

machine (SVM). In order to avoid overfitting for classes with a bigger amount of data in training process, not all the data from the given database was used. For each class exactly the same number of samples was taken into consideration for training, which means that several signals were shortened for not more than 10 minutes. Four different classifiers were trained separately: one for each nominal frequency and for each type of signal (power or audio). The classifiers for audio signals were trained on both audio and power signals, while the classifiers for power signals were trained on power signals only. The data preparation process was the same for all signals. One by one, the signals were fed to ENF extractor block, and the extracted ENF signals were processed by the feature extractor block, which stored obtained features into a table. Each column of this table presents one feature, and each row corresponds to one training data sample. Features were extracted from windows of 600 samples (10 minutes), while the overlap of neighbouring windows was 300 samples. Each window was considered as one independent training data sample. The overlap was used in order to avoid loss of information, as well as to increase the number of training samples. The last window of a signal was taken into consideration only if it lasted more than 480 samples (8 minutes). Different classification problems required specific features, and the ones with the best results were chosen heuristically (Table 1). The function *fitcsvm* provided in MATLAB's Statistics and Machine Learning Toolbox was used to implement the SVM. As the kernel function, radial basis function was used, and parameter *KernelScale* was set to *auto*, meaning that the software uses a heuristic procedure to select the optimal scale value. The parameter *Standardize* was also set, in order to normalize the features.

TABLE I
LIST OF THE FEATURES USED BY EACH OF THE CLASSIFIERS

features	audio		power	
	50 Hz	60 Hz	50 Hz	60 Hz
mean value	x	x	x	
range	x		x	
log(std(wav1))	x			
log(std(wav3))			x	
log(std(wav5))	x	x	x	
log(std(wav7))	x	x	x	
log(std(wav8))	x	x	x	
log(std(wav9))	x	x	x	x
3rd YW coefficient			x	
4th YW coefficient			x	
mean(rise_feature1)				x
max(rise_feature2)			x	
mean(rise_feature2)			x	x
extremes_feature1			x	x
extremes_feature2			x	

* $wavM$ is the wavelet detail of the M -th level; YW stands for Yule-Walker; $rise_feature1$, $rise_feature2$, $extremes_feature1$ and $extremes_feature2$ are all explained in detail in section A

For a system with M classes, a total of $M(M-1)/2$ binary classifiers were trained for every possible pair of the grids, as in [12], which means that M equalled 3 if the nominal frequency value was 60 Hz, and 6 in case of 50 Hz. Depending on the score for the grids compared within each binary classifier, the predicted label was either Grid1, Grid2, or *none-of-the-above* (abbreviated: N). The final decision was based on the number of votes from each binary classifier, where the class with the maximum number of gathered votes is the winner. Since there was a possibility that outcome of all of the classifiers would be *none-of-the-above*, the priority in voting was given to the decision for a grid that belongs to the given dataset. This was achieved by setting a threshold of minimum of 2 hits out of 5 classifiers (case of 50 Hz grids classification), or 1 hit out of 3 classifiers (case of 60 Hz grids classification).

When the classifiers are prepared, the classification of unknown signals can be performed. The signal for which the grid of origin has to be determined will first be fed to the ENF extractor. Based on the output values, which will determine whether the signal is audio or power, and which is its nominal frequency, the signal will be submitted to the corresponding classifier. The feature extractor block will choose only the features necessary for a particular trained classifier, and perform classification. As the result, classifier will return a label of one of the 9 grids from the database, or label N as an indication that the analysed signal does not belong to any of them.

The evaluation of the system was done using cross validation. The power signals, both for 50 and 60 Hz grids, the signals were divided into 5 groups with an almost equal amount of data from each class. In order to artificially increase the amount of audio data, each audio signal was divided into 3 parts and each part was

considered as an independent signal. Consequently, the training/test set consisted of 54 different audio signals from 9 grids instead of 18. For cross-validation, both for 50 and 60 Hz grids, audio signals were divided into 3 groups. The training set was made with 2 out of 3 groups of audio signals and power signals were added into the current training set (for each of the 3 iterations), and the remaining group was used as the test set. The training sets were chosen in described manner, since the results obtained with them gave higher accuracy than the other combination (as shown in Table 2).

The obtained result on the Practice dataset (provided by SP CUP 2016) is the following label sequence:

AHCFG, BGIND, ADBDC, INNAE, HBBAD,
CGHGB, DDCHG, EAIHI, EHECF, GNGEI

The accuracy of that classification is 92%. The obtained result on the Testing dataset is the following label sequence:

NDDCD, GHGAG, ANGBG, BFCEH, GHHGG,
BFDAL, DNFHI, IECBD, ENIBG, FFNAG, IINID,
HAEFC, CCDDG, CECGI, EICEN, BEBHA,
DIHCG, AIBIH, CNDBA, HBFBB

TABLE II
RESULTS IN (%) OF CROSS VALIDATION FOR EACH OF THE CLASSIFIERS

tested on \ trained on	50 Hz power	50 Hz audio	60 Hz power	60 Hz audio
audio	/	69.44	/	77.78
power	86.38	/	95.56	/
power and audio	82.46	75.00	94.38	88.89

IV. CIRCUIT DESIGN

The primary focus in designing the circuit for measurements of local electrical power grid was to deliver a plain and robust solution. Unquestionably, the core functionality can be achieved through several different options. Since the voltage level in wall outlets first must be rescaled to the requested range for data acquisition module, the first step can be carried out by e.g. current transformers, resistive shunts, Hall effect sensors, or Rogowski coils. Apart from data acquisition modules with driver software and USB connection (i.e. "black box" solution), the next step that includes analogue to digital conversion, sampling and file, can be done with various microprocessor units [13]. The solution our team opted for is a combination of proven,

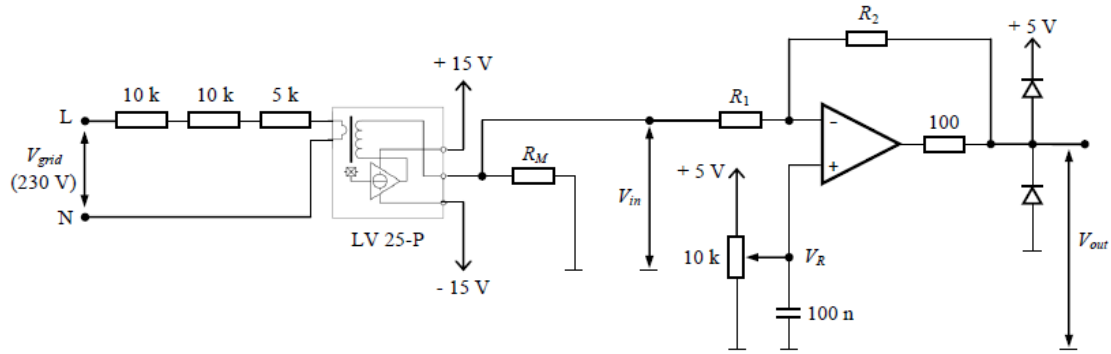

Fig. 6. Circuit for grid voltage measurement using Hall effect sensor LV 25-P.

but for us previously unfamiliar sensing equipment and standard, well-known tools in digital signal processing. The chosen specific realization of afore-described setup consisted of Hall effect sensor, Arduino board and MathWorks MATLAB.

Hall effect sensor is a current transducer based on Hall effect, providing low noise current on the output proportional to the AC/DC current on the input [14]. It is commonly used owing to several distinctive properties: isolation from voltage spikes, modularity and tolerable dimensions. Non-linearity caused by a Hall effect sensor is significantly smaller than due to the conventional current transformer, while the galvanic isolation between the grid and the sensor equipment is retained. The sensor used in our circuit was LV 25-P (manufactured by LEM), with a conversion ratio of 2500:1000, accompanied by 25 k Ω resistors in series (Fig. 6). The ground was common for both the Hall effect sensor and Arduino board.

Arduino UNO, developed by Arduino, of the same name, is a widely available open-source single-board microcontroller (SBM). The output from the Hall effect sensor was fed into Arduino's analogue input pin. Analog input was in the range of 0 to 5 V, and the AD conversion used 10 bits (values from 0 to 1023). The sampling rate, set at 2 kHz, was achieved using the Timer library, available at Arduino's website. The values were sent as ASCII characters for further steps to the UART serial port with baud rate of 112500 b/s.

As for the final piece of the measurement setup, MATLAB from MathWorks was employed to receive the data in digital format from the Arduino board through the aforementioned UART serial port during the predicted time period of 1 hour. Subsequently, the recordings were converted into the desired WAVE format and saved. A minor MATLAB function was written in order to automate the process. The circuit realization is shown in Fig. 7.

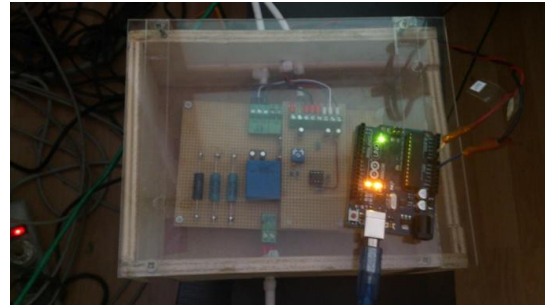

Fig. 7. The equipment for power grid recordings.

V. DATA ANALYSIS

In order to observe fluctuations in the utility frequency of the Serbian network, the power grid was recorded at various times of the day and week. By using the algorithm proposed in this paper, the ENF signal was extracted (Fig. 8, enlarged Fig. 9) from the power recordings made with the aforementioned sensing circuit. The ENF signal in Serbian network has a nominal frequency of 50 Hz.

For the purpose of data analysis, some basic characteristics of the signal were computed: mean value, standard deviation and range of the signal (Table 3). Most of the time, the mean value of the signal is above 50 Hz, as can also be observed in Fig. 9. The range of the signal does not exceed the value of 0.13 Hz. It appears to have smaller values in the morning and in the afternoon, a slight increase in the late afternoon which coincides with the end of the working day, and afterwards, during the night, it decreases again.

By observing and comparing the plots of the ENF signal extracted from these recordings, one can detect certain similarities in behaviour with grids D and F (Table 4). Moreover, the observed characteristics of the signals appear to be similar as well.

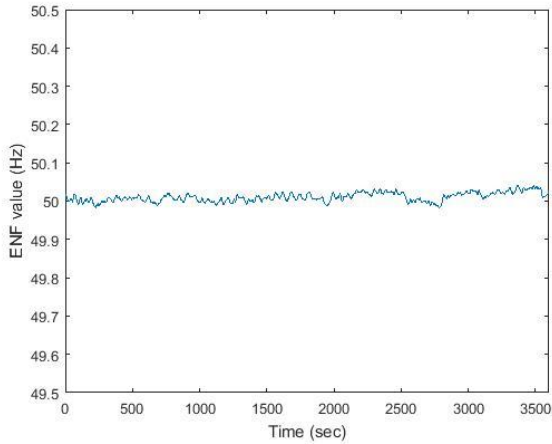

Fig. 8. ENF signal extracted from a power recording made in the morning.

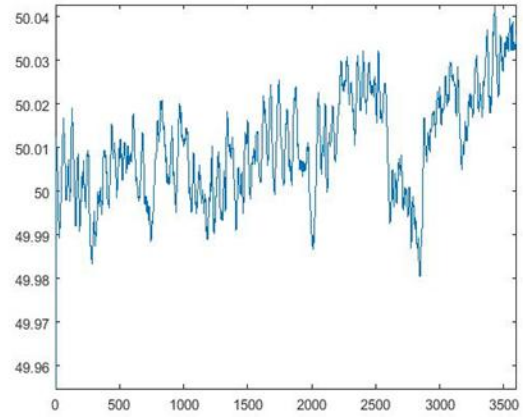

Fig. 9. Zoomed ENF signal extracted from a power recording made in the morning.

TABLE III
LIST OF THE RECORDINGS MADE WITH BASIC CHARACTERISTICS SHOWN.

date(Y/M/D)	time	working day	mean (Hz)	std. deviation (Hz)	range (Hz)
2015/12/30	09:16-10:16	yes	50.0105	0.0118	0.0625
2016/01/05	16:30-17:30	no	49.9967	0.0265	0.1147
2016/01/05	19:12-20:12	no	50.0192	0.0265	0.1314
2016/01/05	22:40-23:40	no	50.0138	0.0260	0.0928
2016/01/06	19:26-20:26	no	50.0208	0.0229	0.1257
2016/01/13	10:05-11:05	yes	50.0298	0.0143	0.0870
2016/01/13	12:05-13:05	yes	50.0291	0.0143	0.0786
2016/01/13	14:05-15:05	yes	50.0176	0.0138	0.0653
2016/01/14	08:50-09:50	yes	50.0023	0.0121	0.0655
2016/01/14	16:40-17:40	yes	50.0034	0.0151	0.0831

TABLE IV
COMPARISON BETWEEN SERBIAN NETWORK AND SIMILAR NETWORKS FROM THE TRAINING SET

	mean (Hz)	std. deviation (Hz)	range (Hz)
Grid F	50.0020	0.0152	0.0716
Grid D	49.9982	0.0159	0.0765
Serbian grid	50.0143	0.0183	0.0907

When compared to other grids with respect to ENF characteristics, Serbian network shows most resemblance to grid D (Fig.10).

V. CONCLUSION

In this paper, a system for extraction and classification of ENF signals from 9 different grids of origin was developed. The ENF from power grid recordings was extracted from the harmonic with the highest peak. The standard ESPRIT method was used for power signals, while in case of audio signals the spectrum was obtained with Discrete Fourier transform. The grid location classifier was based on SVM. For each of the four groups of ENF signals (50/60 Hz, power/audio), a binary classifier with a specific set of

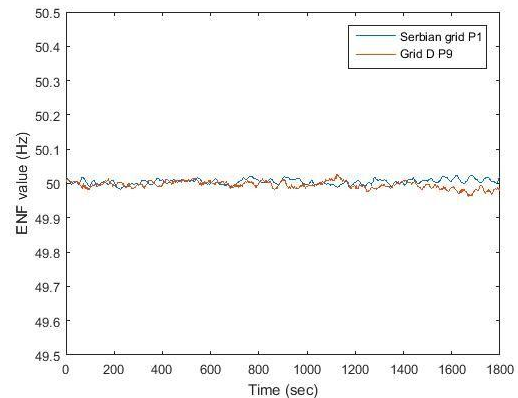

Fig. 10. Signal from Team's grid and one from grid D.

features was trained. The final decision was for the grid with most votes from each of the classifiers. The voting system favoured grids from the database over *none-of-the-above* to balance the expected large number of classifiers with the latter outcome. During the research, grid F was concluded to be the one with least distinctive traits, thus the one hardest to correctly identify. The accuracy scored on Practice dataset was 92%. Since the contribution of the recordings to the Practice dataset is not equal, a weighted average was used to determine the comparable result of cross-validation. When calculated as described, success rate of classification is 86%. The suggestions for further work are the following: improving the resolution of ENF signal extracted from audio recordings, discovering a discriminative feature for grid F and finding an optimal mother wavelet for the specific use in ENF criterion. Beside the system for classification, the sensing circuit is realized with Hall effect sensor and Arduino UNO, and used to obtain over 10 hours of recordings of the Serbian power grid. By observing plots of the extracted ENF signal from those recordings and comparing values of its features, most similarities in behaviour are detected with grid G, followed by D and F.

REFERENCES

- [1] N.Fechner and M.Kirchner, "Background Noise of a Carrier of ENF Artifacts in Mobile Device Audio recordings", 2014.
- [2] M. Kajstura, A. Trawinska and J. Hebenstreit, "Application of the Electrical Network Frequency (ENF) Criterion", *Forensic Science International*, vol. 155, no. 2-3, pp. 165-171, 2005.
- [3] M. Huijbregtse and Z. Geradts, "Using the ENF criterion for determining the time of recording of short digital audio recordings", *Computational Forensics*, Vol. 5718 of the series Lecture Notes in Computer Science pp 116-124, 2009.
- [4] C. Grigoras, "Applications of ENF criterion in forensic audio, video, computer and telecommunication analysis", *Forensic Science International*, vol. 167, no. 2-3, pp. 136-145, 2007.
- [5] C. Grigoras, "Digital audio recording analysis – the electric network frequency criterion", *International Journal of Speech Language and the Law*, vol. 12, no. 1, pp. 63-76, 2005.
- [6] H. Su, A. Hajj-Ahmad, M. Wu and D. W.Oard, "Exploring the use of ENF for multimedia synchronization", *ICASSP 2014 - 2014 IEEE International Conference on Acoustics, Speech and Signal Processing (ICASSP)*, 2014.
- [7] A.J. Cooper, "The electric network frequency (ENF) as an aid to authenticating forensic digital audio recordings – an automated approach", *AES 33rd International Conference, USA 2008*.
- [8] A. Hajj-Ahmad, R. Garg, and M. Wu, "Instantaneous frequency estimation and localization for ENF signals", in *Proc. Of APSIPA Annual Summit & Conf.*, 2012.
- [9] P. Stoica and R. Moses, "Spectral analysis of signals", Prentice Hall, 2005.
- [10]I. Daubechies, "Ten lectures on wavelets", *CBMS-NSF conference series in applied mathematics*. SIAM Ed. 1992.
- [11]R. N. Khushaba, S. Kodagoo, S. Lal, and G. Dissanayake, "Driver Drowsiness Classification Using Fuzzy Wavelet Packet Based Feature Extraction Algorithm", *IEEE Transaction on Biomedical Engineering*, vol. 58, no. 1, pp. 121-131, 2011.
- [12]A. Hajj-Ahmad, R. Garg, M. Wu, "ENF-Based Region-of-Recording Identification for Media Signals", *Information Forensics and Security, IEEE Transactions on*, vol.10, no.6, pp.1125-1136, 2015.
- [13]P. Top, M.R. Bell, E. Coyle, and O. Wasynczuk: "Observing the Power Grid," *IEEE Signal Processing Magazine*, Special Issue on Smart Grid, vol. 29(5), pp. 24---32, 2012.
- [14]M.-A.Paun, J.-M. Sallèse, M. Kayal, "Hall Effect Sensors Design, Integration and Behavior Analysis", *J. Sens. Actuator Netw.* 2, 85-97. 2013.

MEMBERS OF UNSTOPPABLE

Danica Despotović, born in 1993, in Novi Sad, Serbia, is a student of the 4th year of Bachelor studies with major in Communication technologies and signal processing. Upon completion of mathematics and science module in Grammar school "Isidora Sekulić" in 2012, she enrolled in Electrical engineering at the Faculty of Technical sciences of the University of Novi Sad, Serbia. She is a student-member of IEEE and Signal Processing society since 2015. Conducted summer internship at Faculty of Engineering, Prince of Songhkla University, Thailand. Presented a paper at TELFOR 2015 conference which won the "Prof. dr Ilija Stojanović" award for an outstanding student paper.

Milivoje Knežević was born in Novi Sad, Serbia, in 1993. During high school he was a regular participant in mathematical competitions from local to national level. After graduating from Grammar school "Jovan Jovanović Zmaj" (mathematics and science module) in 2012, he enrolled in Electrical engineering at the Faculty of Technical Sciences of the University of Novi Sad, Serbia. He is currently in 4th year of Bachelor studies, with major in Communication technologies and signal processing. While he shows special appreciation and fondness for programming and applied mathematics, finding out backgrounds of great engineers is a hobby of his.

Željana Šarić was born in 1993 in Novi Sad, Serbia. She is a 4th-year Bachelor student of Communication technologies and signal processing. Even as a high school student shows interest for practical application of mathematics and physics. After graduating from Grammar school "Jovan Jovanović Zmaj" in 2012, she enrolled in Electrical engineering studies at the Faculty of Technical Sciences, University of Novi Sad, Serbia.

Tijana Zrnić, born in 1994, in Novi Sad, Serbia, is a 3rd-year student at the Faculty of Technical Sciences, University of Novi Sad, Serbia, majoring in Communication technologies and signal processing. As a student of Grammar school "Isidora Sekulić" she was mostly devoted to mathematics, which resulted in winning the first prize at a national-level competition. Her main interests include signal processing, applied mathematics, machine learning techniques and information theory. Her wish is to combine as many of these as possible in her future scientific development.

Anastazia Žunić, born in Novi Sad in 1995, is a 4th-year Bachelor student of Communication Systems at the Faculty of Technical Sciences, University of

Novi Sad, Serbia. As a student of Grammar school "Jovan Jovanović Zmaj", she participated in the exchange program A-smyle 2011/2012, during which she graduated in the USA. She gained theoretical and practical experience as an intern at Ecole Polytechnique Fédérale de Lausanne (EPFL) within the program Summer@EPFL 2015, where she joined the Audiovisual Communications Laboratory (LCAV). Her principal interests are in the domain of image processing and wireless sensor networks.

Tijana Delić, born in 1992. in Novi Sad, is a student of Master studies at the Faculty of Technical sciences, University of Novi Sad, Serbia, majoring in Signal processing. She graduated from Bachelor studies in Communication technologies and signal processing in 2015 with an average grade of 10.00 and at the top of her class, for which she was awarded the "Prof. dr Ilija Stojanović" award. Her main interests include signal processing with emphasis on speech processing, as well as machine learning and big data.